

CHECKWEIGHERS

FOOD

Higher yield due to reduction of product giveaway

Hygienic Design fostering operational efficiency and safety

High accuracy at top speeds increases line efficiency

Flexible and modular solutions meeting your requirements

ACCURACY
SPEED

HYGIENIC
DESIGN

DURABILITY

FLEXIBILITY

Low total cost of ownership

HIGH-PRECISION AND ULTRAFAST
SOLUTIONS FOR MAXIMUM **EFFICIENCY**
IN **INDUSTRIAL FOOD PRODUCTION**



CHECKWEIGHERS

A Wipotec Company

OUTSTANDING HIGH-TECH FOR THE HIGHEST PRECISION AT MAXIMAL THROUGHPUT RATES

OCS CHECKWEIGHERS

- 3 Food checkweighers**
Unsurpassed speed and precision in a modular hygienic design
- 4 Wipotec Group and OCS Checkweighers**
All expertise under one roof: globally respected, independent, flexible and innovative
- 6 Comscale4**
OCS networked software tailored for central data analysis
- 7 EMFR – Electro-Magnetic Force Restoration**
High precision at top speeds

MACHINE SYSTEMS

- 8 EC-E series**
Compact design, big performance
- 10 EC-E-VA**
Compact technology in stainless steel design
- 11 EC-E Options**
Modular design for your individual requirements
- 12 HC-M series**
High precision for mid-range speeds
- 14 HC-M-VA**
Solid stainless steel checkweigher for wet areas
- 15 HC-M-WD**
Robust washdown design for maximum hygiene
- 16 HC-M-MDi**
Weighing and metal detection in one integrated unit
- 17 HC-M**
Diverse options for your custom application
- 18 HC-A series**
For the highest standards in dynamic weighing
- 20 HC-A components**
Top quality modules for your success
- 21 HC-A-VA**
The all-rounder in solid stainless steel for wet areas
- 22 HC-A Options**
Maximal flexibility for tailor made solutions
- 24 HC-A-Multi**
High performance checkweighers for multi-track operations
- 25 HC-A-MI**
Precision weighing for the lightest objects
- 26 HC-A-MDi**
Weighing plus metal detection for maximum product safety
- 27 Heavy load checkweighers**
Precision weight determination for heavy loads

X-RAY AND OPTICAL INSPECTION

- 28 X-ray inspection systems**
Brand protection through food inspection and safety checks
- 29 SC-W**
Space-saving combination of checkweigher and x-ray inspection
- 30 SC-V**
X-ray inspection and optical checks integrated in one structural design

SERVICE

- 31 Reliable expert service**
Our comprehensive knowledge network is available to you anywhere in the world

MODULAR CHECKWEIGHERS TAILORED TO THE REQUIREMENTS OF YOUR FOOD PROCESSING OPERATIONS

Checkweighers are highly precise measuring instruments that have become an integral part of today's industrial manufacturing processes. Almost every branch proceeds from the premise that combining high precision with the maximum possible throughput rates will maximise profit. Whereas underfilled products may lead to costly recalls and irreparable damage to your reputation, overfilling of products will have a negative effect on your productivity data. The highly precise weight measurement of your products is clearly a decisive factor in terms of the quality of your production. Moreover, it is a criterion that affects your long-term market position.

MAXIMUM FLEXIBILITY FOR YOUR APPLICATION

Decades of experience as a supplier of dynamic weighing and inspection systems has provided OCS the knowledge of what criteria are needed to produce a top quality product range. For that reason, OCS checkweighers have the flexibility and the variety of product configurations to enable a perfect customisation for your individual application needs. The checkweighers from OCS possess outstanding technology combined in a hygienic design (from the standard model to the fully hygienic variant), which consistently measures up to the stringent requirements of the food industry. Beyond pure weight value determination, these checkweighers optimize your production processes with robust, high-tech machines that are simple to operate and quick and easy to clean. Outstanding precision is achieved through the use of EMFR Weigh Cell technology from Wipotec.

EASY TO COMBINE AND INTEGRATE

To maximize product safety, OCS checkweighers can be combined in a compact design with additional inspection devices such as metal detectors or X-ray scanners.

The compact weighing and inspection systems from OCS Checkweighers are easily integrated in existing production lines. They are characterised by their safety, durability, and dependability - for you, the practical and perfect technology investment for a prosperous future.



ALL THE EXPERTISE UNDER ONE ROOF: MEET OCS CHECKWEIGHERS

HEADQUARTERS WIPOTEC GROUP



OCS Checkweighers is a fully owned subsidiary of the high-tech specialist Wipotec. The dynamic, fast, and highly accurate weighing and inspection systems from both companies have been the reliable standard for more than 25 years. OCS has provided solutions in the production lines of leading producers in the pharmaceutical, food, chemical, and cosmetics industries, in addition to the mail and logistics sectors.

EXCELLENCE IN STANDARD AND CUSTOM-BUILT MACHINES

Wipotec and OCS stand for sophisticated high-tech systems with maximum ease of use. The impressive product portfolio provides solutions for nearly all customer applications. If necessary, we take special requirements and conditions into account in supplying customised equipment.

EXTRAORDINARY MANUFACTURING DEPTH, ALL SIDE BY SIDE

OCS contributes great importance to the in-house development of all necessary technologies as well as the in-house manufacturing of all core components. Consequently, we develop a depth of manufacturing that differentiates us from other vendors and makes us largely independent of suppliers, while forming the basis for our delivery reliability.

At OCS, the entire value chain from basic research, to planning, design, and manufacture to sales and service is all under one roof. The benefit of short channels of communication is the guarantee of maximum flexibility in the implementation of every individual product configuration. No matter how unusual your application may be, we will show you a possible solution that is sure to convince you. That's what makes the difference!

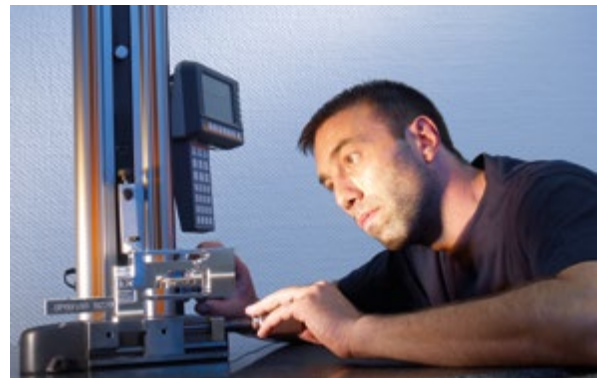

GLOBALLY RESPECTED, INDEPENDENT, FLEXIBLE, AND INNOVATIVE: THAT IS OCS CHECKWEIGHERS

- ☑ GLOBALLY RESPECTED PARTNER IN INDUSTRY FOR MORE THAN 25 YEARS
- ☑ WORLDWIDE PRESENCE THANKS TO NUMEROUS SUBSIDIARIES AND PARTNERS
- ☑ FOUNDER MANAGED COMPANY
- ☑ COMPANY WITH HIGH INNOVATION POWER THROUGH LARGE R&D EFFORT, INCL. BASIC RESEARCH
- ☑ ALL EXPERTISE COMBINED UNDER ONE ROOF
- ☑ IN-HOUSE PRODUCTION OF ALL KEY COMPONENTS
- ☑ BROAD PRODUCT RANGE FOR ALMOST EVERY APPLICATION
- ☑ BROAD EXPERIENCE IN IMPLEMENTING CUSTOMER-SPECIFIC SYSTEMS
- ☑ USE OF HIGH PRECISION WIPOTEC WEIGHING SYSTEMS FOR OPTIMUM PRODUCT QUALITY
- ☑ MEMBER OF THE EUROPEAN HYGIENIC ENGINEERING & DESIGN GROUP (EHEDG)
- ☑ OUTSTANDING SERVICE CAPABILITIES

OCS WEIGHING TECHNOLOGY IS USED WORLDWIDE

About 20,000 checkweighers from OCS Checkweighers have been successfully deployed worldwide. This figure is a confirmation of the outstanding expertise from the company. An unbeatable product range and exceptional service are reason enough for a number of well-known firms in all industries around the world to choose our reliable weighing and inspection systems.

COME AND VISIT US!

Interested in the high-tech solutions from OCS? Perhaps you would like to visit our ultra-modern plant. Our prominent market position is no accident, but rather the logical consequence of the creative and competent efforts made by our staff on behalf of our customers. Come and see for yourself. Just schedule an appointment for a tour with us!



Comscale4: WEB-BASED NETWORK ENABLED SOFTWARE FOR THE CAPTURE AND ANALYSIS OF RELEVANT PRODUCTION DATA

A main factor in increasing production efficiency is a regular and exact analysis of all available production data. This is especially true in large factories and multi-site operations that are dependent on a flexible, web-based quality data management system like Comscale4, the system provided by OCS.

The user-friendly software components from OCS, customised for your needs, connect any number of checkweighers and other inspection machines (x-ray scanner, metal detectors) to separate selectable sites. At any time, you can retrieve all available data,

generate statistics, take important actions, and share data with partners throughout the enterprise. Comscale4 provides the ideal overview of your entire production in real time. Your quality assurance starts here!

Comscale4 - Basic functions

SAFETY	Loss-free data transfer in real time
TRANSPARENCY	Full data view from any site for all integrated machines and lines
CONTROL	Operate/parameter changes via PC and mobile phones
REVIEW	Data analysis, storage, and graphical evaluation for further higher-level use
FLEXIBILITY	Integration of various inspection devices (checkweighers, metal detectors, x-ray scanners, etc.)



Comscale4 - Quality data management for the entire company

PRODUCTION	Central production records and data collection, prepackage regulations documentation and online monitoring all linked to the production lines
QA	Targeted analysis of QA features, random attribute and calibration check
ADMINISTRATION	Tracking metrics and documentation of operating performance
MANAGEMENT	Decisions of the highest priority



Comscale4: Powerful web-based software for perfect quality and production control

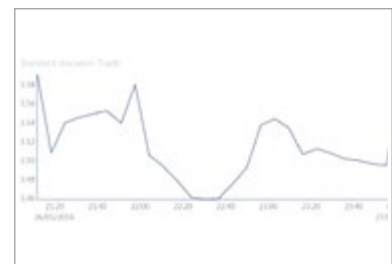
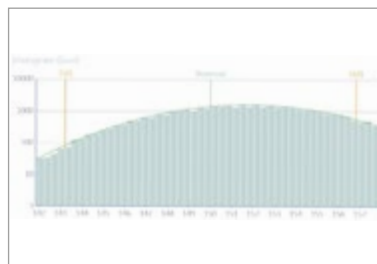
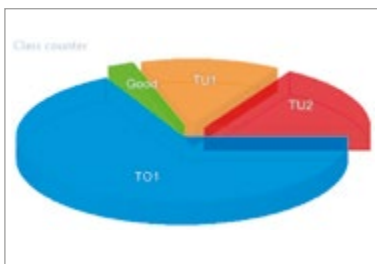

EMFR - ELECTRO-MAGNETIC FORCE RESTORATION

The decisive advantage of the Wipotec EMFC Weigh Cells is provided by their very short settling time. They are extremely fast and supply highly accurate weight values in comparison to other measuring methods that rely on strain gauges. Furthermore, they provide space and cost savings when integrated in existing systems.

EMFR - THE PRINCIPLE OF ELECTRO-MAGNETIC FORCE RESTORATION

OCS weighing systems operate on the principle of electro-magnetic force restoration (EMFR). The weighing method can be compared in principle to a simple beam balance. The objective is to determine the force applied at one end of a lever arm. In this case, the weight forces the coil installed on the other side of the balance out of a magnetic field. An optical positioning system senses the smallest displacement and reports this to a high precision control system that readjusts the compensation current and restores equilibrium to the balance. The compensation current is measured through a precision resistor and further processed by a micro-processor system for immediate output as a digital weight value. OCS checkweighers with EMFR weigh cells provide the winning edge. Depending on the series, the measurement range goes from 1 microgram to 120 kilograms.

AVC (ACTIVE VIBRATION COMPENSATION): GREATEST ACCURACY IN CHALLENGING ENVIRONMENTS

EMFR Weigh Cells from Wipotec can be equipped with AVC technology, as required. AVC (Active Vibration Compensation) technology filters out all operational interference that could affect the measuring results, thereby enabling the use of the weighing system in locations that are not free from external sources of vibrations (for example, forklift traffic).

CONFORMITY MARKING OF AUTOMATIC CHECKWEIGHERS IN COMPLIANCE WITH MID

OCS is certified according to ISO 9001 and authorized to carry out a conformity evaluation according to module D of the "Measuring Instruments Directive" (MID, 2014/32/EU). The directive bindingly regulates and harmonizes for all EU Member States, EFTA as well as Turkey the key requirements relating to measuring devices and their commissioning.

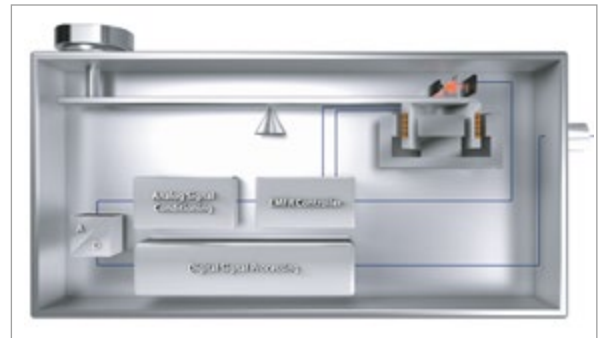

EMFR weigh cells enable lightning-fast weighing results

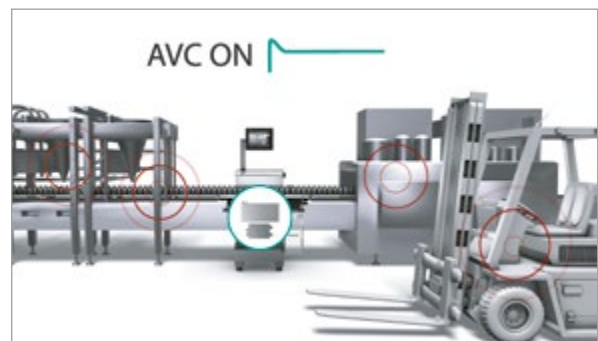

AVC compensates for disturbances from external vibrations

→ Watch the video for more information



OCS customers benefit from MID in several ways:

- ✔ **Installation, commissioning, and conformity assessment (formerly, initial verification) from one supplier**
- ✔ **Trade barriers eliminated within the EU**
- ✔ **A homogeneous level of protection by means of harmonized technical requirements**

COMPACT DESIGN, BIG PERFORMANCE:

EC-E BASIC

Reliability and transparency of production data are the basis of all planning. The **EC-E** checkweigher from OCS Checkweighers guarantees 100% data capture in ongoing production.

Capable of 150 weight values per minute, the EC-E is the right choice for you. The intuitive user interface ensures convenient operation via a clearly structured, 8-inch colour touchscreen. The EC-E checkweigher precisely weighs each individual product, records individual values, and ejects incorrect weight packages via the fully

automated sorter. Your data is correctly and completely collected and you have the certainty that only factory compliant products leave your production halls.

The checkweighers ease of use virtually excludes all incorrect entries. A reliable high-tech machine, especially in the dry foods

sector, with a very good price-performance ratio in the EMFR entry segment.



MAIN FEATURES

- ✔ Wipotec EMFR Weigh Cells
- ✔ Stainless steel frame
- ✔ Stainless steel cabinet with integrated control system
- ✔ Three NT30 belts (infeed, weighing and outfeed conveyors); Lightweight construction
- ✔ Maintenance-free servo drives
- ✔ One sorter attachment (air blast)
- ✔ User friendly interface via 8" colour TFT touchscreen display
- ✔ Memory for 50 different product parameters (option to expand to 200)
- ✔ Line synchronisation with potential-free switching contacts/binary signals
- ✔ Extensive statistical functions/histograms

YOUR BENEFITS

- ✔ High throughput rate of up to 150 ppm/min
- ✔ Precise and reliable weighing results to increase plant efficiency
- ✔ Very good price-performance ratio
- ✔ Requirements-based modularity for the greatest flexibility

TECHNICAL DATA

Working height	650-800/750-900/850-1,000/950-1,100 mm		
Belt width	150/200/300 ¹⁾ mm		
Infeed belt	300/400/500/600 mm		
Outfeed belt	300/400/500/600 mm		
Weighing belt	200/300/400/500 ¹⁾ mm		
Weight range	EC-E-1	EC-E-2	EC-E-3
Gross weight range	1,500 g	3,000 g	6,000 g
Display value	≥ 0.2	≥ 0.5	≥ 1.0
Calibration value	≥ 0.5	≥ 1.0	≥ 2.0
Standard deviation²⁾	from 150 mg		
Max. output²⁾	150 ppm		
Rated voltage; rated frequency	L1/N/PE; 100-240 VAC; 50/60 Hz		
Power capacity	approx. 0.8 kVA		
Compressed air supply	6 bar approx. 10 NI/min		
Tare weight	100 kg		
EC-certified	DE-08-MI006-PTB028 (MID)		

1) Option, additional price

2) Dependent on product form, product behaviour, transport speed and local conditions



Other machine specifications
 → Technical Data Sheet



EC-E-SL for large and heavy product formats



The EC-E product series for reliable weighing

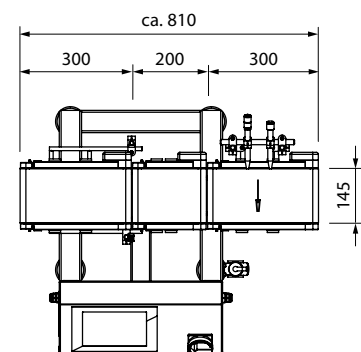
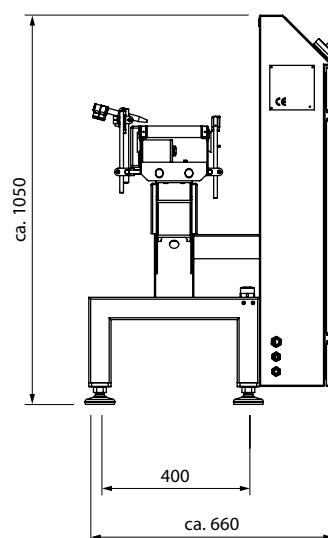
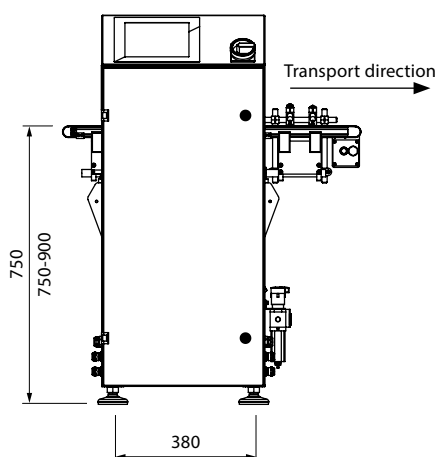

All entries in mm | Drawing shows sample version

COMPACT TECHNOLOGY IN STAINLESS STEEL DESIGN FOR USE IN WET ENVIRONMENTS

EC-E VA

The **EC-E-VA** model has an innovative design with weigh cells, drives, and belt construction in stainless steel (protection class IP 65) and is recommended for use in light to average humidity environments.

The Wipotec Weigh Cell used operates on the principle of Electro-Magnetic Force Restoration (EMFR) and stands for the fastest high precision measurement results. The EC-E-VA is fast and easy to integrate in

any production line. This machine is your reliable instrument for optimal efficiency with up to 150 weight values per minute.

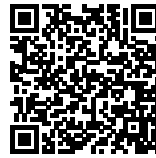

Other machine specifications
→ Technical Data Sheet

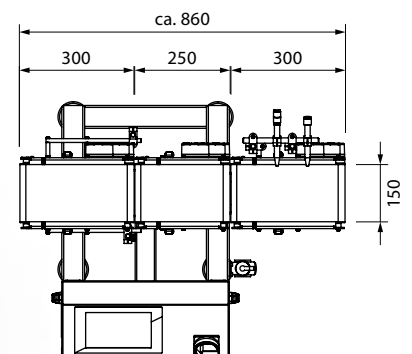
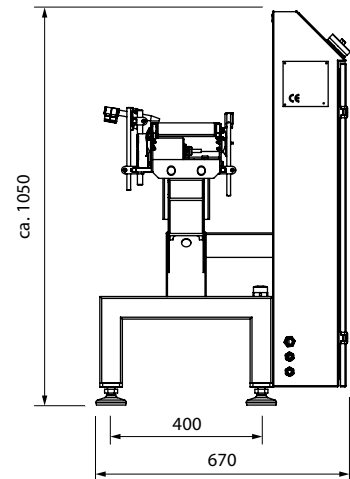
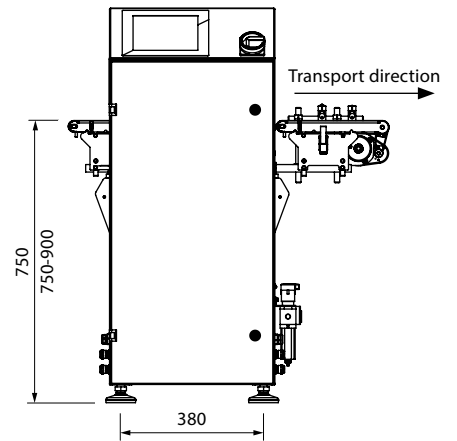

All entries in mm | Drawing shows sample version

EC-E: MODULAR DESIGN FOR YOUR INDIVIDUAL NEEDS

Mechanics

1

- ✔ Various belt lengths and widths
- ✔ Additional NT30 conveyor belt
- ✔ Metal detector belt NT30
- ✔ Special working heights
- ✔ Support leg

Product handling

2

- ✔ Lateral guide rails
- ✔ Rolling knife edge
- ✔ Bridge plate between belts

Statistics/Data export

3

- ✔ USB Stick
- ✔ Single value transfer
- ✔ Comscale4
- ✔ Paper roll printer
- ✔ Standard interfaces
- ✔ Connection to Freeweigh.Net

Monitoring functions

4

- ✔ Product flow control
- ✔ Pressure switch
- ✔ Fill level check/collector box
- ✔ Emergency stop (various versions)
- ✔ Metal detector connection

Weighing technology

5

- ✔ Fully covered weighing belt as protection against draughts
- ✔ Approved variant available
- ✔ Performance of MID conformity assessment (formerly, initial verification)

Electrical options

6

- ✔ Lamp tower (one or three step)
- ✔ Signal horn
- ✔ Supplemental potential-free I/O

Sorting Options

7

- ✔ Pusher
- ✔ Free standing hinged flap
- ✔ Flipper
- ✔ Second sorter
- ✔ Rejection bin, lockable
- ✔ Stainless steel drop shaft

Control functions

8

- ✔ Mean value regulation (for filler head)
- ✔ Expandable item storage

HIGH PRECISION FOR THE AVERAGE SPEED RANGE

HC-M BASIC

The dynamic checkweighers of the **HC-M** series provide the perfect weighing technology for challenging medium range checkweighing applications. They are the link to the series EC-E and HC-A scales and provide up to 250 weight values per minute for the complete medium range.

The HC-M is the most convenient answer, whether you need to check the current actual weight or perform a completeness check, or a sort, or a classification. The base frame is made of solid stainless steel and enables high precision weight determination at average to high conveyor speeds or throughput rates and provides

100% product checks in accordance with national prepackage regulations. The lightweight, patented conveyor system and carefully tuned drive concept ensure smooth, fast and safe transport. Component design facilitates implementation of custom solutions for various product shapes and forms.

A sophisticated and wide range of sorters (pusher, air blast, etc.) are available for the reliable ejection of products having an incorrect weight, without interfering with the production.

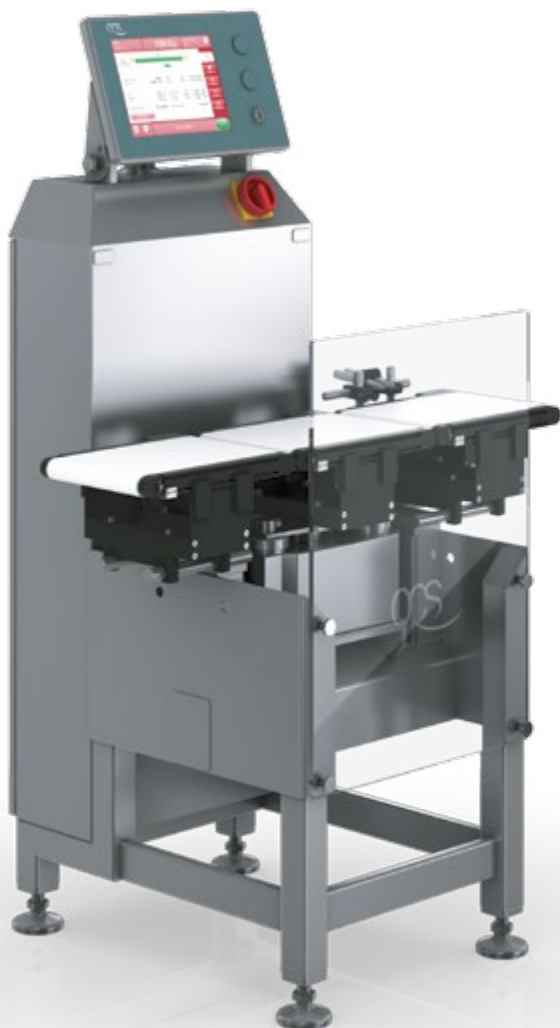

MAIN FEATURES

- ✔ Entire machine in stainless steel housing with infeed, weighing, and outfeed belts (NT30)
- ✔ One sorter attachment (air blast)
- ✔ Maintenance-free servo-drives
- ✔ Certified (MID)
- ✔ Wipotec EMFR Weigh Cells
- ✔ Simple, menu-directed operation on 10.4" colour TFT touchscreen
- ✔ Memory for 100 product parameters
- ✔ Easy, tool-free exchange of belts and conveyors
- ✔ Flexible integration in production lines
- ✔ Line synchronisation with potential-free I/O signals
- ✔ Extensive statistical functions/histograms for production documentation

YOUR BENEFITS

- ✔ Maximum throughput 250 ppm/min
- ✔ Exact fill results for higher productivity
- ✔ Efficiency improvement through simple and user-friendly controls
- ✔ Requirements-based modularity for the greatest flexibility

TECHNICAL DATA

Working height	700-850/800-950/900-1,050 mm
Belt width	120/150/200/300 ¹⁾ /400 ¹⁾ mm
Infeed belt	200/300/400/500/600 mm
Outfeed belt	200/300/400/500/600 mm
Weighing belt	200/250 ¹⁾ /300/400/500 mm
Gross weight range	750-7,500 g
Display value	from 0.1 g
Min. calibration value	0.1 g-1.0 g
Standard deviation²⁾	from 100 mg
Max. output²⁾	250 ppm
Rated voltage; rated frequency	L1/N/PE; 100-240 VAC; 50/60 Hz
Power capacity	approx. 0.8 kVA
Compressed air supply	6 bar approx. 10 NI/min
Tare weight	120 kg
EC-certified	DE-08-MI006-PTB028 (MID)

1) Option, additional price

2) Dependent on product form, product behaviour, transport speed, and local conditions



Other machine specifications
→ Technical Data Sheet



Simple operation: Colour TFT display with touchscreen

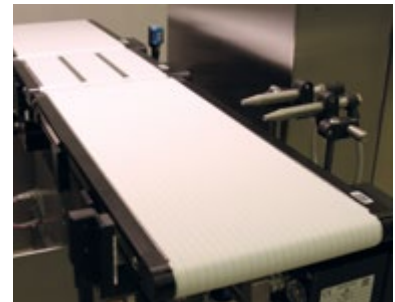

Air blast nozzle for secure ejection of under or overweight products

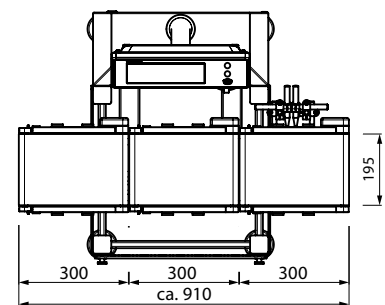
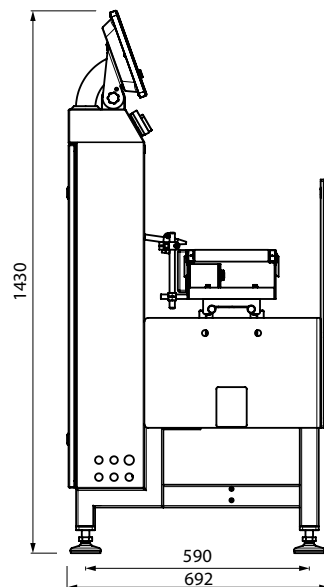
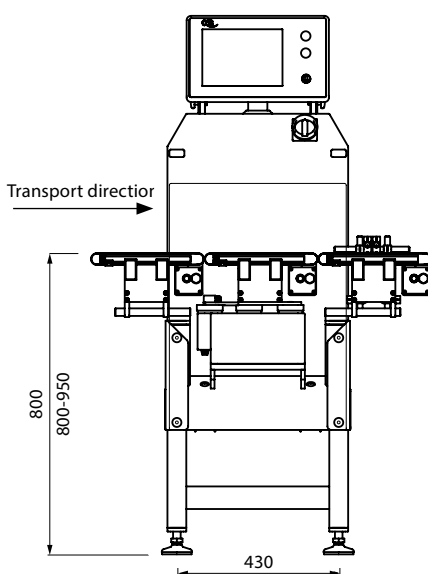

All entries in mm | Drawing shows sample version

THE CHECKWEIGHER IN A SOLID STAINLESS STEEL VERSION FOR WET ENVIRONMENTS

HC-M VA

The solid stainless steel construction of the **HC-M-VA** is the perfect answer. Other materials have been deliberately avoided in the product areas. This makes the HC-M-VA ideal for use in light to average humidity environments (protection class IP 65).

The Weigh Cell with secondary hood, drive motors, and conveyors are all manufactured as stainless steel machine components. Additional options in stainless steel complete this outstanding package. The stainless steel version of the HC-M-VA is a prime example of machine design as

well as for product and consumer safety. Designed and implemented for frequent cleaning cycles, this machine very easily integrated in existing production lines.



Other machine specifications
→ Technical Data Sheet

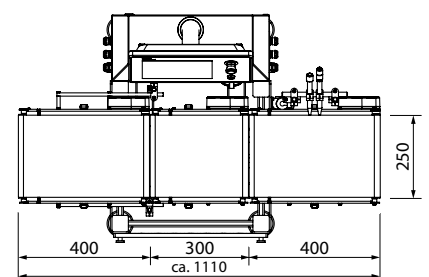
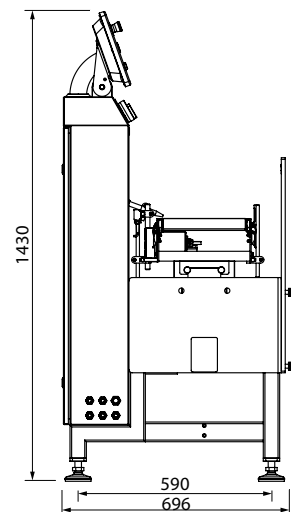
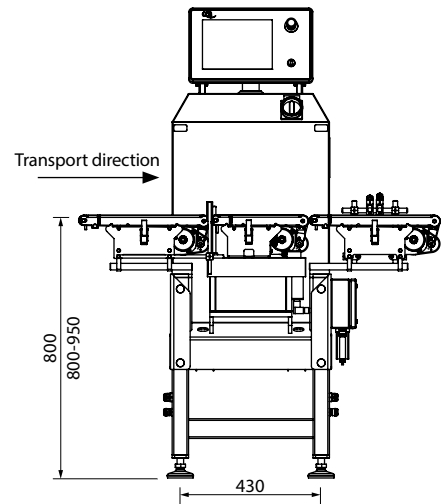

All entries in mm | Drawing shows sample version

WASHDOWN DESIGN FOR UNIVERSAL USE AND MAXIMAL HYGIENE

HC-M WD

The **HC-M-WD** from OCS Checkweighers provides a reliable and robust checkweigher in an innovative, hygienic washdown design. This model meets all statutory provisions for the food processing industry like IFS-compliant product control, and HACCP or LMHV/FDA (Food Hygiene Regulations).

OCS developed these dynamic checkweighers, which deliver outstanding values in terms of precision and throughput, to be maintenance-free, with stainless servo motors for use in operations with intensive and frequent cleanings. The well-designed performance features of the HC-M-WD model satisfy all cleaning criteria and the most stringent hygienic requirements of the food industry.

Rounded surfaces and defined drip edges in combination with an open design and protection class IP 69K provide the best conditions for optimal hygiene. Ease of cleaning is ensured by the tool-free removal of the belts (excenter). An optional cleaning program package enables risk-free cleaning while in operation. The machine underframe is also hygienically designed. The stainless steel design of the precision

weigh cell with sloping housing and separate base for a vibration-free integration in the machine frame ensures reliable and highly precise results.



Other machine specifications
→ Technical Data Sheet

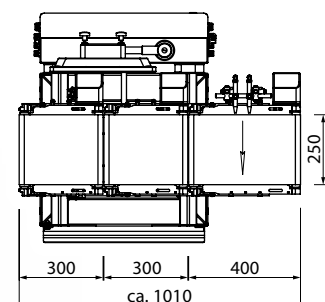
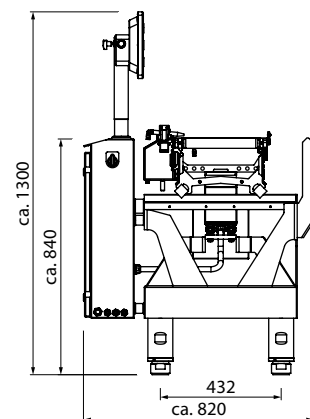
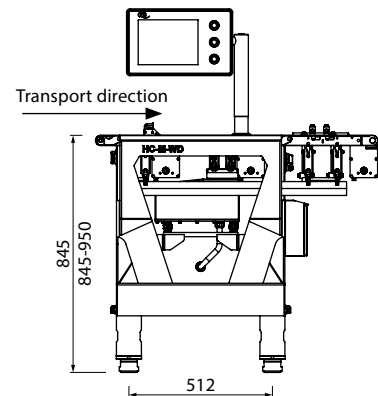

All entries in mm | Drawing shows sample version

WEIGHING AND METAL DETECTION IN ONE INTEGRATED UNIT

HC-M MDi

If high precision weighing of your products is not enough and you require an additional reliable inspection for metallic impurities, you need the **HC-M-MDi**. This machine is a high-tech combination scale and metal detector, together in one compact unit that sets the quality standard in terms of product safety.

The entire system is controlled via the menu-driven, user-friendly controls of the checkweigher. The central control point conveniently manages the product parameters, protocols, and production statistics. Naturally, you will find all of the conventional performance characteristics

of metal detectors (for example, product tracking, compensating for the product effect, FPV compliance checks, etc.), provided in the HC-M-MDi. This model is a high-precision weighing instrument and fully integrated metal detector all in one compact unit.



Other machine specifications
→ Technical Data Sheet

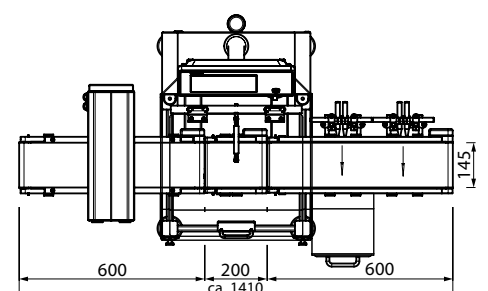
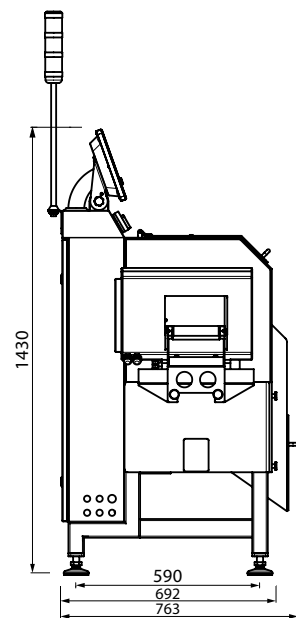
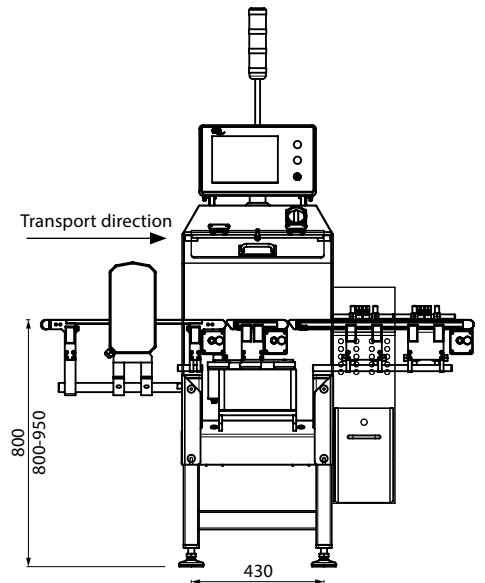

All entries in mm | Drawing shows sample version

HC-M: DIVERSE OPTIONS FOR YOUR CUSTOM APPLICATION

Mechanical options

1

- ✔ Various belt lengths and widths
- ✔ Requirements-based transport system
- ✔ Free standing conveyor belt
- ✔ Combination frame (for metal detector)
- ✔ Metal detector belt
- ✔ Special working heights
- ✔ Support leg

Product handling

2

- ✔ Lateral guide rails
- ✔ Rolling knife edge
- ✔ Bridge plate between belts
- ✔ Fully adjustable settings for top belts, scooped belts, and lateral pressure belts
- ✔ Intralox linked chain belts

Statistics/Data export

3

- ✔ USB Stick
- ✔ Configurable statistics transfer
- ✔ Comscale4
- ✔ Paper roll printer
- ✔ XML and OPC interface
- ✔ Standard interfaces (profibus, Ethernet/IP)
- ✔ Connection to Freeweigh.Net
- ✔ Backup/Restore program package

Monitoring functions

4

- ✔ Product flow control
- ✔ Serial fault detection
- ✔ Sensor control
- ✔ Additional product controls (flaps, inclined angles)
- ✔ Pressure switch
- ✔ Fill level check/collector box
- ✔ Emergency stop (various versions)
- ✔ Potential-free infeed

Weighing technology

5

- ✔ Fully covered weighing belt as protection against draughts
- ✔ Approved variant available
- ✔ Performance of MID conformity assessment (formerly initial verification)
- ✔ Weigh cell with preload adjusted noise compensation
- ✔ Multi-interval/multi-range scale

Electronic options

6

- ✔ Lamp tower (one or three step)
- ✔ Signal horn
- ✔ Expandable product parameter memory
- ✔ Control over max. 5 transport drive motors
- ✔ Interfaced frequency converter
- ✔ Numerical remote display
- ✔ Supplemental potential-free I/O
- ✔ Integrated metal detector

Sorting options

7

- ✔ Pusher
- ✔ Free standing hinged flap
- ✔ Flipper
- ✔ Second sorter
- ✔ Rejection bin, lockable
- ✔ Stainless steel drop shaft

Control functions

8

- ✔ Mean value regulation (for single filler head)
- ✔ Mean value regulation (for dual filler heads)
- ✔ Floating mean value control
- ✔ Minimised ejections

FOR THE HIGHEST STANDARDS IN DYNAMIC WEIGHING

HC-A BASIC

In terms of precision and throughput, checkweighers of the **HC-A** series are the logical response to meet the demands of modern, dynamic weighing technology. The machines provide the controls and engineering to create the ideal platform for implementing the complex regulation and control tasks. The HC-A is the basis for high end application-oriented systems that provide a maximum of 600 values per minute with 100% product monitoring.

This model significantly extends the application possibilities of the OCS product line and completes our versatile product range, especially for high-end applications. This machine continues the use of our successful product and operating concept. In particular, the advanced solid stainless steel frame ensures extremely accurate weighing results at very high transport

speeds or throughput rates. The modular design facilitates the implementation of custom solutions for a variety of product geometries and forms. The sophisticated and wide selection of sorters (pusher, air blast, etc.) is designed to reliably eject products with incorrect weights with respect to packaging. The HC-A is characterised by its comprehensive product hand-

ling. For example, the top runner belts safely perform acceptance and acceleration of folded cartons just as the metering screw and lateral pressure belts safely separates and accelerates vials and bottles. The HC-A supports your efforts to minimise costly overfilling with a number of optional functions.

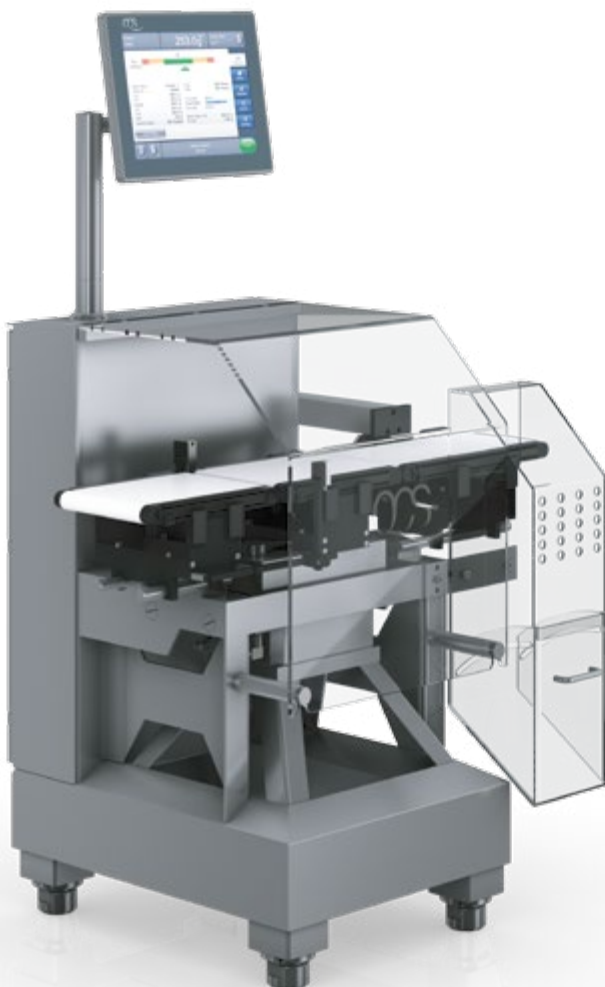

MAIN FEATURES

- ✔ **Sturdy, solid stainless steel frame**
- ✔ **One sorter (air blast or pusher)**
- ✔ **Maintenance-free servo-drive**
- ✔ **Certified (MID)**
- ✔ **Wipotec EMFR Weigh Cells**
- ✔ **Simple, menu-directed operation via a 15" colour TFT touchscreen**
- ✔ **Easy, tool-free exchange of belts and conveyors**
- ✔ **Flexible integration in production lines**
- ✔ **Line synchronisation with potential-free I/O signals (expandable option)**
- ✔ **Variable conveyor belt widths and lengths**
- ✔ **Extensive statistical functions/histograms**

YOUR BENEFITS

- ✔ **Maximum output 600 ppm/min**
- ✔ **Exact fill results for highest productivity**
- ✔ **Efficiency improvement through simple and user-friendly controls**
- ✔ **Requirements-based modularity for the greatest flexibility**
- ✔ **Greater unit efficiency means a positive contribution to reducing TCO**

TECHNICAL DATA

Working height	700-850/800-950 /900-1,050 mm
Belt width	120/150/200/300/400 ¹⁾ mm
Infeed belt	200/300/400/500/600 mm
Outfeed belt	200/300/400/500/600 mm
Weighing belt	200/250 ¹⁾ /300/400/500 mm
Gross weight range	750 g - 7,500 g
Display value	from 0.05 g
Min. calibration value	0.1 g-1.0 g
Max. output²⁾	600 ppm
Standard deviation²⁾	from 50 mg
Rated voltage; rated frequency	L1/N/PE; 100-240 VAC; 50/60 Hz
Power capacity	approx. 0.8-1.0 kVA
Compressed air supply	6 bar approx. 10 NI/min
Tare weight	220 kg
EC-certified	DE-08-MI006-PTB028 (MID)

1) Option, additional price

2) Dependent on product form, product behaviour, transport speed, and local conditions



Other machine specifications
 → Technical Data Sheet



Easy to comprehend and operate: HC-A user interface



State-of-the-art HC-A weighing technology as multi-track option

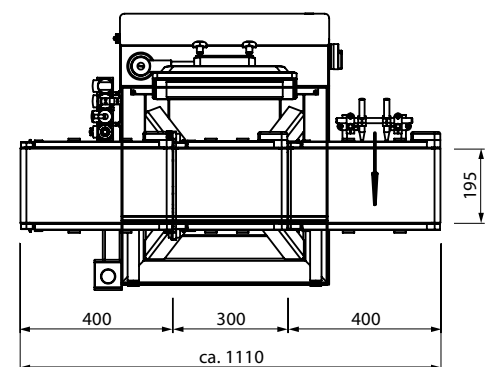
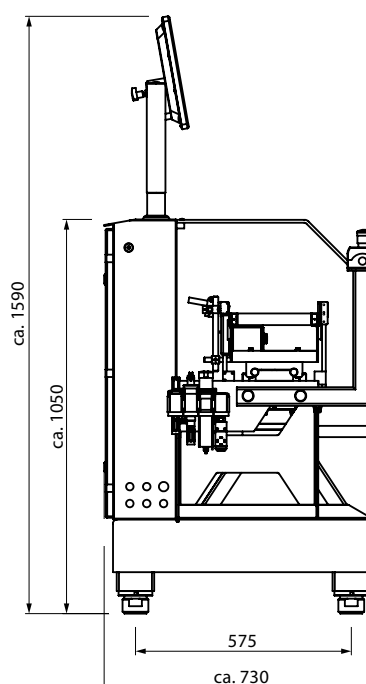
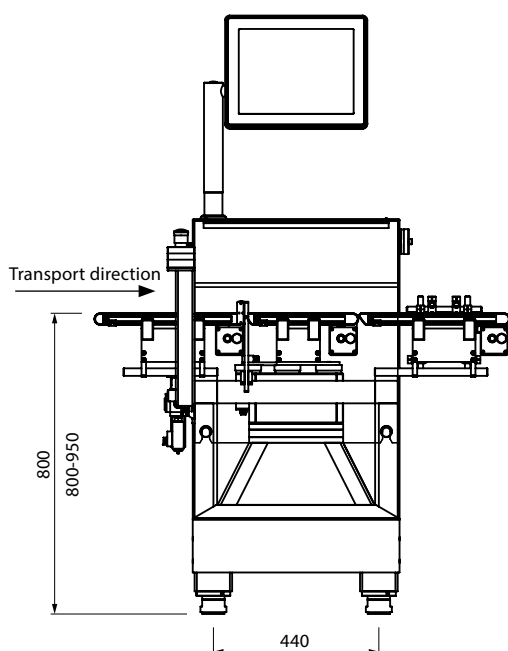

All entries in mm | Drawing shows sample version

HC-A MODULES: HIGH QUALITY COMPONENTS FOR YOUR SUCCESS

The sure and correct choice of checkweigher components is the basis for efficient dynamic weighing. Many years of experience in the design and manufacture of dynamic weighing systems lets you profit from the perfectly matched interplay of high precision weighing and high transport speeds.

GMP COMPLIANT DESIGN

The consistent implementation of GMP requirements (for example, sloped edges, hidden cable channels, easy to clean surfaces) ensures an easy integration of the HC-A in food production operations.

STURDY FRAME

An especially robust underframe made of stainless steel ensures in conjunction with the integration weight, a secure foundation that safely dampens any spurious vibrations (for example, fork lift traffic)

PATENTED CONVEYOR SYSTEM

The lightweight, patented conveyor belts together with a carefully tuned drive concept, ensure the very smooth, safe, and reliable transport. In addition, the transport system is supplemented with a variety of handling systems (for example, metering screws).

PRECISION WEIGH CELLS

Designed especially for the requirements of dynamic high performance weighing, the weigh cells (1 ms sampling value) are optimally adjusted for each application. The highest accuracy, fastest speeds, and highest productivity are safely achieved.

15-INCH COLOUR TFT

The HC-A is equipped with a large high resolution colour TFT touchscreen. The display features a brilliant, high-contrast colour scheme.

PRODUCT FLOW CONTROL

The optional product flow control monitors the product chain within the checkweigher and initiates an alarm if:

- Additional products wrongly enter the product flow
- Registered products are removed from the product flow
- A faulty product is mistakenly not ejected (cross verification in the accepted goods flow)

REMOTE OPERATION

The scales of the HC-A series can be remotely operated via an Ethernet-connection from a second control panel (option).

SEQUENTIAL DRIVE

The HC-A checkweighers employ a motor management system that continuously governs the individual drive motors. If the transport speed of an upstream machine changes, the HC-A simultaneously maintains the metrological accuracy and automatically adjusts the sorting time (sequential drive optional).

FLAP CONTROL

The flap control option checks the proper closure of the packages. Improperly closed packages detected by the checkweigher are reliably ejected at the sorter. In the production statistics, improperly closed packages are recorded separately. The flap controls are sizing parts that can be easily set by a graduated dial for different package sizes.

SENSOR CONTROL

Another option is the continuous monitoring of all connected sensor by the checkweighers. The failure of a sensor - perhaps a loose cable - automatically triggers an alarm. A plain text alarm message stating the type sensor is displayed.

FLOATING MEAN VALUE CONTROL

The floating mean value control option enables the self-adjustment of the sorter dead zone for long wave variations of the package weights. The sorter's dead zone and the accepted goods zone are adjusted by means of the calculated floating mean value to a predefined tolerance range set by the user for the current production. The floating mean value control allows a narrow choice of selection limits while taking into account the variations in package weight within the production run.

TOP QUALITY COMPONENTS FOR YOUR SUCCESS

HC-A VA

The **HC-A-VA** dynamic checkweighers in solid stainless steel provide the highest standards of precision and maximum throughput. This means the HC-M-VA (protection class IP 65) is ideal for use in light to average humidity environments and easily integrated in existing production lines. As machine components, the weigh cells, motors, and conveyors are also constructed from stainless steel.

” For many years, our poultry farm has relied on the high-precision weighing technology from OCS Checkweighers. We appreciate the innovative engineering approach and the outstanding service provided by OCS. The checkweighers are very easy to operate and provide 100% product checks with reliable

ejection systems. These machines are extremely well-suited for use in washdown environments thanks to the stainless steel design and their incredible accuracy.”

Claus Foldager
Head of Technology at HKScan
Vinderup, Denmark



Other machine specifications
→ Technical Data Sheet

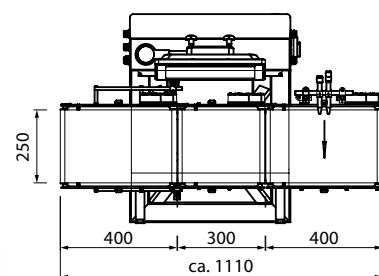
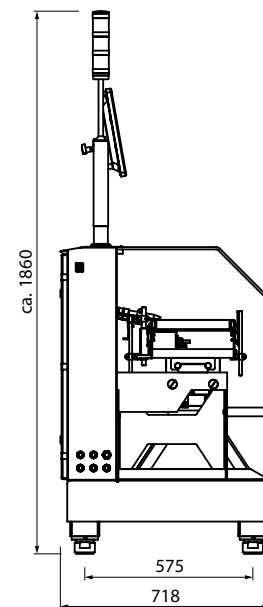
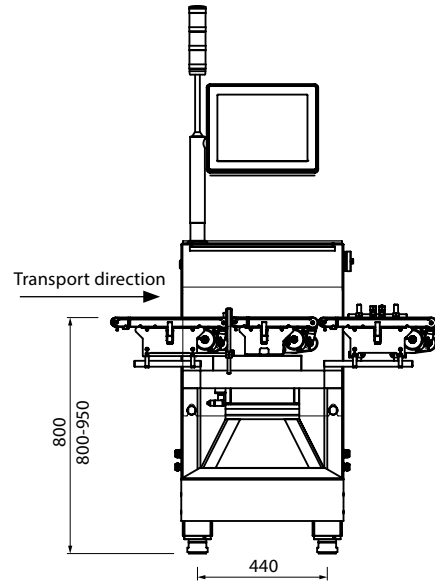

All entries in mm | Drawing shows sample version

HC-A OPTIONS: MODULAR COMPONENTS FOR YOUR OPTIMISED APPLICATION



The HMI of the HC-A offers simple and intuitive operation, convenience and ease of learning.



User-friendly homescreen



Clear graphics of mean value indication

Type	Date	Time	Accepted
Intermediate statistics	2011-04-12	11:50:10	Yes
Complete statistics	2011-04-12	11:50:10	Yes
Complete statistics	2011-04-12	11:50:45	Yes
Complete statistics	2011-04-12	11:50:10	Yes
Complete statistics	2011-04-12	11:50:10	Yes
Complete statistics	2011-04-12	11:50:10	Yes
Complete statistics	2011-04-12	11:50:10	Yes
Complete statistics	2011-04-12	11:50:10	Yes
Complete statistics	2011-04-12	11:50:10	Yes
Complete statistics	2011-04-12	11:50:10	Yes

Extensive statistical functions

HC-A: VARIOUS MODULE OPTIONS AT A GLANCE

Mechanics

1

- ✓ Various belt lengths and widths
- ✓ Multi-track unit with combined operation
- ✓ Application-based transport system
- ✓ Combination base frame (metal detector, laser coding, etc.)
- ✓ Metal detector conveyor
- ✓ Special working heights
- ✓ Support leg

Product handling

2

- ✓ Lateral guide rails
- ✓ Rolling knife edge
- ✓ Bridge plate between belts
- ✓ Fully adjustable settings for top belts, scooped belts and lateral pressure belts
- ✓ Metering screws
- ✓ Intralox linked chain belts

Statistics/Data export

3

- ✓ USB Stick
- ✓ Configurable statistics transfer
- ✓ Comscale4
- ✓ Paper roll printer
- ✓ XML and OPC interface
- ✓ Standard interfaces (profibus, Ethernet/IP)
- ✓ Connection to Freeweigh.Net
- ✓ Backup/Restore program package

Monitoring functions

4

- ✓ Product flow control
- ✓ Serial fault detection
- ✓ Sensor control
- ✓ Additional product controls (tabs, inclined angles)
- ✓ Pressure switch
- ✓ Fill level check/collector box
- ✓ Emergency stop (various versions)
- ✓ Adjustment controls
- ✓ Traffic sensors

Weighing technology

5

- ✓ Preload adjusted noise compensation
- ✓ Active Vibration Compensation (AVC)
- ✓ Tara-gross weighing system
- ✓ ml-software program
- ✓ Fully covered weighing belt as protection against draughts
- ✓ Approved variant available
- ✓ Performance of MID conformity assessment
- ✓ Multi-interval/multi-range scale
- ✓ Multi-track weighing system
- ✓ Item „Teach-In“

Electronic options

6

- ✓ Lamp tower (one or three step)
- ✓ Signal horn
- ✓ Expandable product parameter memory
- ✓ Control over additional transport drive motors
- ✓ Mixed motor operation (IMOT or DC/AC motors)
- ✓ Interfaced frequency converter
- ✓ Numerical remote display
- ✓ Chaotic product range
- ✓ Supplemental potential-free I/O
- ✓ Sequential drive
- ✓ Integrated metal detector

Sorting

7

- ✓ Multiple sorts
- ✓ Sorters (air blast, pusher, flaps, etc.)
- ✓ Supplemental sorter systems
- ✓ Rejection bin, lockable
- ✓ Stainless steel drop shaft and container
- ✓ High speed discharge system
- ✓ Servo-drive discharge system

Control functions

8

- ✓ Mean value regulation (for up to 30 filler heads)
- ✓ Remote maintenance control
- ✓ Filler head monitor with trend meter and individual statistics (for up to 30 filler heads)
- ✓ Floating mean value control
- ✓ Minimised ejections

HIGH PERFORMANCE CHECKWEIGHERS FOR MULTI-TRACK OPERATIONS

HC-A MULTI

The **HC-A multi-track systems** are particularly well-suited for use with small package sizes (for example, stick packs or 4-sided sealed bags). Multi-track units are available in conventional conveyor belt systems and also as a push over variant. High-precision weight measurements with individual display are provided for each track (with the minimal mid-lane positioning). The rejection system can be track based or combined.

In the push over variant, the EMFR-Weigh Cell from Wipotec is completely decoupled mechanically from the product transport. Products are pushed by a „finger“ (guided and driven from above) onto the weighing platform. The product transport is centrally managed by only one servo drive for the entire checkweigher (all tracks). The smallest feasible track separation and maximal

accuracies are achieved using the push over method. Multi-track units are custom designed, developed, and manufactured to your specific requirements, dependent on the filling unit in operation and the product geometries.



Other machine specifications
→ Technical Data Sheet

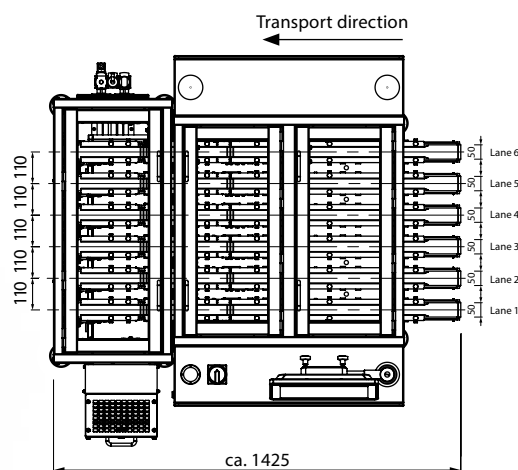
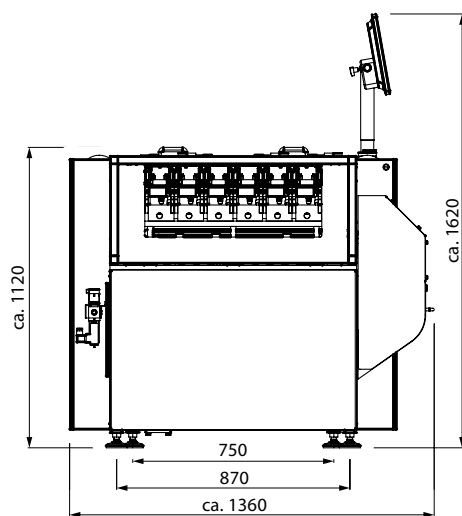
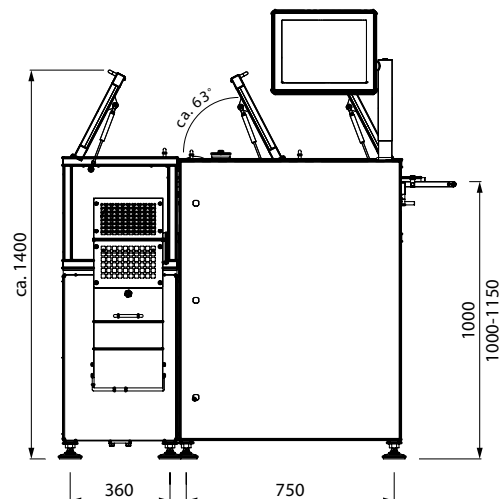

All entries in mm | Drawing shows sample version

PRECISION WEIGHING FOR THE LIGHTEST OBJECTS

HC-A MI

The **HC-A-MI** is the perfect automated system for continuous and accurate weighing of ultra-lightweight parts (for example, stick packs) in the milligram range. Product infeed is product-specific and individually managed.

Vibrations in the production environment are suppressed through preload adjusted noise compensation (optional). Weight values are determined within fractions of a second. The classification of either accepted or rejected products, as well as the subsequent sorting, is done directly by the controls of the checkweigher.

Because of its automated 100% monitoring, the HC-A-MI provides new possibilities in quality assurance for sensitive products and production processes. It is easily integrated into any production line.



Other machine specifications
 → Technical Data Sheet

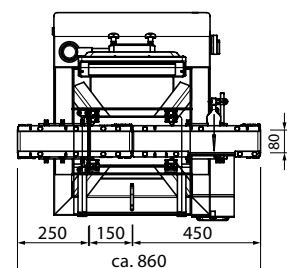
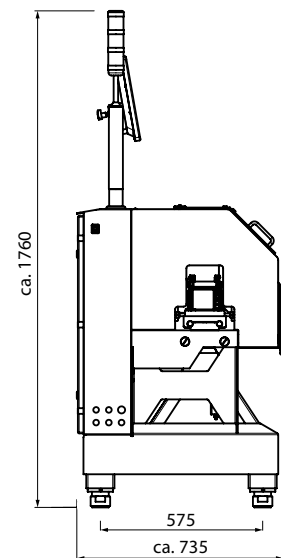
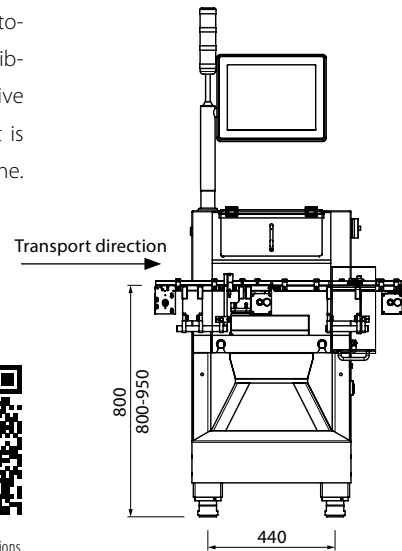

All entries in mm | Drawing shows sample version

WEIGHING PLUS METAL DETECTION FOR MAXIMUM PRODUCT SAFETY

HC-A MDi

The **HC-A-MDi** model is synonymous with high precision weighing in combination with extremely sensitive metal detection for optimal performance. It is a practical combination of inspection technologies in the interests of increased consumer safety and provides scales and metal detector in one space-saving unit, which can be operated from one HMI and easily integrated as part of any line.

” The technical flexibility of OCS Checkweighers is primarily what convinced our company. The machines feature a compact and robust design with efficient controls. These checkweighers and metal detectors perform a very accurate control of our dairy products with outstanding reliability and quality and practically no main-

tenance costs. This is the reason we can recommend, without reservation, OCS Checkweighers as a top supplier of high-precision weighing and inspection systems.“

Willi Tauber,
General Manager Brimi,
Vahrn, Italy

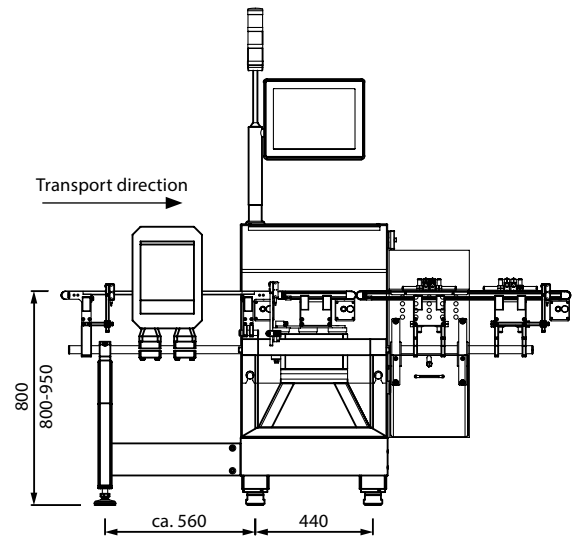

Other machine specifications
→ Technical Data Sheet

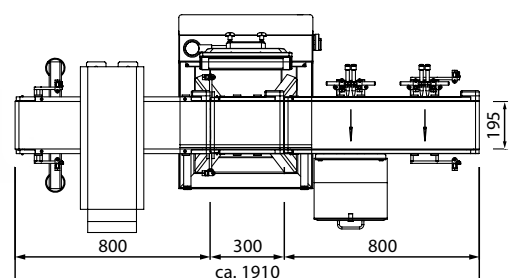
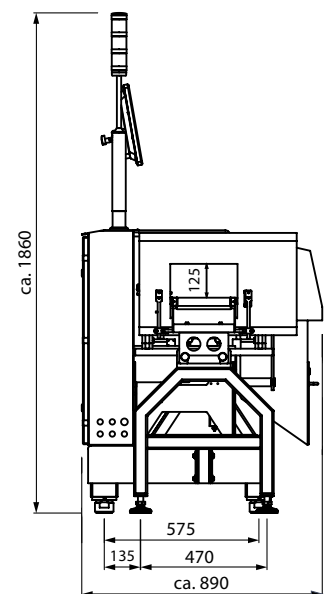

All entries in mm | Drawing shows sample version

HEAVY LOAD CHECKWEIGHERS FOR PRECISE WEIGHT DETERMINATION

Do you need a reliable checkweigher for precise, dynamic weighing processes in the field of logistics and warehousing or in a wet-room with strict hygienic requirements? Your investment in a heavy duty model from the comprehensive line of checkweighers from OCS Checkweighers is surely the right decision. The scales determine precise weight values while controlling goods and material flows and providing remarkable throughput rates facilitated by high speed operations. Simple to use and easy to integrate in your existing conveyor systems, these machine guarantee the highest precision and service life.

OCS portfolio of heavy load checkweighers:

EC-E-SL - the entry machine

HC-M-SL - base model with a gross weighing range up to 60 kg

HC-M-WD-SL - for heavy loads in washdown applications (IP 69K)

HC-M-MDi-SL - in combination with metal detection



EC-E-SL
Other machine specifications
→ Technical Data Sheet

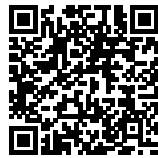

HC-M-SL
Other machine specifications
→ Technical Data Sheet



Other machine specifications
→ Technical Data Sheet



HC-M-WD-SL



Other machine specifications
→ Technical Data Sheet



HC-M-MDi-SL

ADVANCED X-RAY TECHNOLOGY FROM OCS: ENSURING PRODUCT SAFETY AND BRAND PROTECTION ARE OUR BIGGEST PRIORITIES

In the industrial manufacturing of products, quality must be given the highest priority in all production processes. Against the backdrop of utmost concern for customer safety, supplying defective goods can quickly result in fatal consequences. Recall actions are extremely costly and may irreparably damage your image as a reliable producer. Even worse are the health risks passed on to the consumer because defective products were shipped.

OCS INSPECTION SYSTEMS - GUARANTEE OF QUALITY

To ensure the shelves at the retailer do not become a safety risk, manufacturers need advanced and fully automated inspection systems that reliably and continuously guarantee quality without restricting productivity.

OCS is among the leading suppliers of comprehensive inspection systems worldwide. Our globally recognised cutting edge technology and our comprehensive product range of ultra-modern, high performance X-ray scanners give you the confidence of knowing you are in the best possible position in terms of quality assurance. Together with you, we create the foundation for sustained customer loyalty.

X-ray scanners from OCS support the efficient design of quality assurance systems on the basis of standards like HACCP, BRC, or IFS. These high-tech machines detect foreign bodies made of metal, glass, stone and plastics of different densities while checking your products for completeness, correct form and fill quantities.



More information
→ X-ray brochure

OCS PORTFOLIO OF X-RAY- AND OPTICAL INSPECTION SYSTEMS



- SC** **Scanning** – Premium X-ray inspection for high performance applications
- E** **Essential** – X-ray inspection for basic applications, best price-performance ratio

CHECKWEIGHER AND X-RAY INSPECTION IN A SPACE SAVING UNIT

SC W

The **SC-W** series is a pioneering combination of innovative X-ray technology and the proven checkweigher technology from OCS. The products in the accepted goods stream are checked not only for impurities, but also undergo a high-precision weight control check. Units with an incorrect weight are ejected into a separate container.

Both the single and the dual-track model are very successful – either with or without the curtain for radiation protection. The variant without protective curtain provides high throughput rates of up to 300 packages per minute per track, which is even possible for very lightweight product units.

The tool-free exchange of all conveyor belts and the easy to handle housing

make it really simple to clean the system. The product area is separated from all of the drive system components.

All of the x-ray scanners from OCS have the same familiar and convenient user interface found in the checkweigher line. The system is controlled from a 15" colour TFT display with touchscreen panel that always shows the current x-ray image and product weight. Designed for protection class IP 65 with full stainless steel con-

struction, the system features a balcony design and sloped surfaces that, together with C-shaped product area, enable thorough cleaning, quickly and easily. All scanners meet the most stringent standards of hygiene.



Other machine specifications
→ Technical Data Sheet



MAIN FEATURES

- ✔ X-ray scanner and checkweigher in one unit
- ✔ Flexible component design
- ✔ Available as single or dual-track system

YOUR BENEFITS

- ✔ X-ray scanner and checkweigher for maximum product safety
- ✔ Easy to operate central user interface

X-RAY AND OPTICAL INSPECTION IN A COMPACT UNIT

SC V

The **SC-V** model represents the most advanced inspection technology. It combines reliable detection of product impurities by means of the high performance X-ray scanner with additional optical control systems developed in-house at OCS.

These control systems check the information as it appears on the products (ingredients, nutritional values, expiry date) for correctness and a flawless appearance regarding the proper positioning and readability of all labels and seals. Both inspection units – X-ray system and optical control – are combined in one space-saving design.

In addition to the reliable detection of foreign bodies, the SC-V also guarantees the accurate and uniform appearance of

your products. The model constitutes an outstanding inspection system that provides maximum safety and prevents costly recalls resulting from product contamination or incorrect labelling.

This model has the same familiar and convenient user interface used in the checkweigher line. The system is controlled from a 15" colour TFT display with touch-screen panel that always shows the current image. Designed for protection class IP 65 with full stainless steel construction,

the SC-V system features a balcony design and sloped surfaces that, together with C-shaped product area, enable thorough cleaning quickly and easily. This machine also meets the most stringent standards of hygiene.

Other machine specifications
→ Technical Data Sheet



MAIN FEATURES

- ✔ Multiple inspection methods in one compact unit
- ✔ Legibility check and position control of all labels and codes
- ✔ Cover film verification
- ✔ Verification of best-before date
- ✔ Bar code check
- ✔ Flexible component design
- ✔ Highest hygienic standards
- ✔ Both inspection units operated from one HMI

YOUR BENEFITS

- ✔ The broadest inspection for maximum productivity and product safety
- ✔ Easy to operate central user interface

OCS – DEPENDABLE EXPERT SERVICES, CUSTOMISED FOR YOUR NEEDS

When you choose OCS as your system supplier, you have the benefit of top quality service modules that incorporate the vast experience of our weighing and inspection system experts. Whether a pure consulting service or specific line and product support throughout the product life cycle, we are your reliable partner.

Turn to us with your requirements. We would be pleased to discuss the scope and effort of individual services in more detail with you. Trust in the experience and reliability of OCS.

BENEFIT FROM THE OUTSTANDING RANGE OF OCS-SERVICES

- ☑ 24/7* – HOTLINE AVAILABILITY
- ☑ GLOBAL SERVICE NETWORK WITH CERTIFIED OCS-TECHNICIANS FOR ON SITE SUPPORT
- ☑ PROFESSIONAL INSTALLATION AND OPTIMISATION BASED ON CUSTOMER NEEDS ENSURES SMOOTH START-UP
- ☑ EUROPE-WIDE CONFORMITY ASSESSMENT AND COMPLETE OVERHAUL WITH THE EXCHANGE OF VERIFICATION RELEVANT PARTS
- ☑ PREVENTIVE MAINTENANCE, SETUP, AND OPTIMISATION OF YOUR OCS-PRODUCTS
- ☑ FAST ON SITE REPAIRS USING ORIGINAL PARTS
- ☑ CALIBRATION CHECKS AND READJUSTMENT OF THE ENTIRE SYSTEM, IF REQUIRED
- ☑ GENERAL PRODUCT AND TARGET OBJECTIVE TRAINING TO IMPROVE EFFICIENCY
- ☑ REMOTE MAINTENANCE FIRST HAND (WITH APPROPRIATE HARDWARE) FOR URGENT JOBS

* On conclusion of a corresponding service agreement



INNOVATIVE, HIGH-END INSPECTION SYSTEMS FOR BETTER IMPROVED EFFICIENCY AND PRODUCTIVITY

DE

EN

ES

FR

IT



**WE ARE THE IDEAL PARTNER FOR ALL
YOUR NEEDS, FROM PRE-SALES
CONSULTING TO AFTER SALES SERVICE**



A Wipotec Company

Headquarters:
OCS Checkweighers GmbH
Adam-Hoffmann-Str. 26
67657 Kaiserslautern
Germany

T +49.631.34146-0
F +49.631.34146-8690
info.ww@ocs-cw.com
www.ocs-cw.com

Your **OCS-Local**
Partner



160808 | 1605
All errors and misprints reserved. Data subject to modifications.
Stated trademarks are property of the respective owners.